

## AQUACAL 1" / AQUACAL 3/4"



### Dosatori proporzionali di polifosfato Polyphosphate salt feeder



#### DESCRIZIONE/DESCRIPTION

Dosatori di polifosfato in polvere conforme DM 174/04 e UNI EN 1210 per acque destinate al consumo umano.

*Polyphosphate salt feeder conformity to DM 174/04 and UNI EN 1210 for water intended for human consumption.*



#### CARATTERISTICHE TECNICHE/TECHNICAL FEATURES

- Testa/Head: PP;
- Attacco/Connection: Ottone/Brass;
- Vaso/Sump: SAN trasparente/Transparent SAN;
- Soffietto/Bellow: gomma NBR/rubber NBR;
- O-ring/O-Ring: NBR;
- Pressione di esercizio/Working pressure: max 6 BAR;
- Pressione di scoppio/Burst pressure: max 25 BAR;
- Temperatura di esercizio/Operating temperature: max 25°C;
- Dosaggio/Dosing: 2-4 ppm/mc<sup>3</sup>;
- Portata consigliata/Suggested flow-rate: 3,5 mc<sup>3</sup>/h;
- Autonomia carica/Charge autonomy: 30 mc<sup>3</sup> circa;
- Ricarica/Refill: 100g.



Montaggio sia orizzontale  
che verticale.  
*Horizontal and vertical mounting.*

Codice Code	Modello Model	Ingresso/Uscita Inlet/Outlet	Tipi ricambio Replacement type	Dimensioni (mm) AxBxExC Dimensions (mm) AxBxExC	Imballo / Pack			Contenuto Sale Salt quantity	Price (€)
					Singol	Multiple	Pz.		
A8020120	Aquacal	3/4"F	Polvere/ Dust	91x202x139x3/4"F	228x155x100H	465x575x352H	10	300 gr.	
A8020130	Aquacal	1"F	Polvere/ Dust	91x202x139x1"F	228x155x100H	465x575x352H	10	300 gr.	
A8020125	Aquacal	3/4"F	1 Cartuccia/Cartridge	91x202x139x3/4"F	228x155x100H	465x575x352H	10	1 cart.	
A8020135	Aquacal	1"F	1 Cartuccia/Cartridge	91x202x139x1"F	228x155x100H	465x575x352H	10	1 cart.	
A8020290	Aquacal	3/4"	Vuoto	91x202x139x3/4"F	228x155x100H	465x575x352H	10	/	
A8020270	Aquacal	1	Vuoto	91x202x139x1"F	228x155x100H	465x575x352H	10	/	



#### RICAMBI E ACCESSORI/

#### SPARE PARTS AND ACCESSORIES



A6010050



A6010060



A6010052

Codice/Code	Descrizione/Description	Price (€)
A6010050	Confezione da 500 gr di sale di polifosfato (per 5 riempimenti) 500gr Plastic container with polyphosphate (sufficient for 5 refills)	
A6010060	Confezione da 1000 gr di sale di polifosfato (per 10 riempimenti) 1000gr Plastic container with polyphosphate (sufficient for 10 refills)	
A6010052	Confezione da 3Pz cartuccia ricambio polifosfato AQUA CAL 3/4"11" Replacement cartridges AQUA CAL 3/4" - 1", 3 pcs per pack	



#### DIMENSIONI/DIMENSIONS:

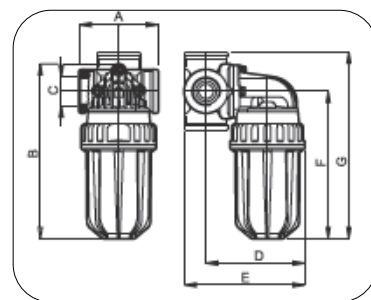

AQUACAL 1" - 3/4"